



DEFINITION OF A SAFE BARRIER FOR A MOTORCYCLIST

– a literature study

Maria Nordqvist, the Swedish Motorcyclists Association, SMC

Göran Fredriksson, Swedish Safety Barrier Association, SVBRF

Jan Wenäll, the Swedish National Road and Transport Research Institute, VTI

May 2015

DEFINITION OF A SAFE BARRIER FOR MOTORCYCLISTS

This final report is made through a donation from “Skyltfonden” and the Swedish Transport Administration. Any conclusions, positions or methods in the report reflects the authors and does not have to be in line with the views, conclusions, positions or methods in this field of the Swedish Transport Administration.

The literature review was conducted by a team of experts; project manager Maria Nordqvist, SMC, Göran Fredriksson, SVBRF and Jan Wenäll VTI. Global research, studies and statistics have been collected and studied. A workshop with participants from different areas in Sweden, Norway and ERF in Brussels was held 20th February when a draft of the literature study was presented along with seminars with researchers from Germany and USA. This is the final report from the literature study and the workshop.

Summary of conclusions

The best barrier for a motorcyclist is no barrier at all. If the barrier itself is more dangerous than what it is designed to protect, no guard rail should be installed. Since there are bridges, threes, steep mountain roads, oncoming traffic and other obstacles in the road environment, there will always be a need of barriers to protect the road users on roads and bridges. But, a barrier is never safe, only less dangerous than the risk behind the barrier.

According to all tests carried out, barriers with Motorcycle Protection System, MPS, gives the lowest risk of injury, whether the rider slides into the barrier or is sitting on the motorcycle. We therefore choose the term MPS in the future since it gives positive effect, mainly in sliding but also in a sitting collision. In a collision where the rider is sitting, sharp edges and corners as well as posts sticking up over the barrier has a major significance for the outcome of injuries. Most studies show a lower risk of injury for collisions with concrete barriers compared to the w-profile and cable barriers, some displays of comparable severity.

Guardrails with unprotected posts and protruding parts lead to the most serious injuries. Smooth barriers without unprotected posts, provide less risk of injury. Several studies have excluded accidents with cable barriers depending on the low number of accidents. The risk of injury in collisions with cable barriers was higher than all other barrier types in some studies, while the risk of injury corresponded to a collision with W-profile in a few studies.

We have chosen not to analyze discontinuous MPS, with protection around the poles, since they give very little reduction in risk of injury. There is also a risk that the rider slide between the posts and collide with the obstacles that the guardrail is intended to provide protection for.

The distance from the road is important for both avoidance of accidents and the risk of injuries.

The most common injuries in guardrail accidents are legs, head, chest and pelvis. All studies show a very high risk of being killed or seriously injured when motorcyclists collide with guardrails.

The technical specification TS 1317-8 specifies a test method in which a dummy slid with head first into a guardrail at an angle where few accidents happen. It is a method that could be simplified, without reducing the safety for motorcyclists.

It is easy to reduce the risk of injury to motorcyclists in terms of both the design of the guardrail and the installation. There is enough knowledge and experience to come to decisions that will increase the safety of motorcyclists in terms of design and installation.

It is difficult to draw fair conclusions from international research. There are huge differences in the barriers used in different countries, the extent of barriers installed and how the barriers are installed. This makes a comparison more difficult to make since one type of barrier can be used very rare or not at all. This is the case concerning concrete barriers in Sweden.

CHAPTER 1. BACKGROUND

1.1 Literature study

Literature has been collected, mainly via Google Scholar and our global contacts. We have mainly looked for studies that highlighted three issues we have seen as important factors for the motorcycle safety.

1. Injuries or risk for injuries from different types of barriers
2. Injury risk depending on barrier design and type of barrier
3. Injury risk depending on installation of barriers

In addition, we compared data on Swedish motorcycle accidents against barriers with the rest of the world. Existing test methods has to some extent been analyzed, even if this part of our application for funding was rejected.

There is much research on the area and it grows as the number of killed and injured motorcyclists in barrier accidents increases. Most studies are done in Australia, New Zealand and the United States. Germany has conducted studies

before and after MPS and other road safety measures were conducted. Unfortunately this literature is only available in German which reduces the understanding. Studies have also been conducted in Spain and Italy.

When it comes to concrete actions based on existing knowledge and experience, Norway has progressed furthest in Scandinavia. The Norwegian Public Roads Administration has a chapter in “Handbook for rekkverk (N101)” with clear requirements for the selection of barriers and the part of the roads where MPS should be installed. Spain and Portugal are the countries in Europe which have invested most in MPS for motorcyclists. Spain has developed a test method and set aside large sums for the retrofitting of MPS. Portugal has a regulatory framework since 2004 with demands for where MPS must be installed to increase motorcycle safety. Germany, as previously mentioned, also has a program for installation of MPS on popular motorcycle routes. Australia and New Zealand is aiming to install MPS, mainly black spots and popular motorcycle routes.

1.2 Share of fatal motorcyclists in barrier accidents

Six motorcyclists were killed in collisions with barriers in Sweden 2014, out of a total of 29 killed in two-wheel motorcycle accidents. The share of motorcyclists killed in Sweden in barrier accidents varies between 10-20 percent per year. The corresponding share in the USA 5.5, Australia 5.4 and 8-16 percent in Europe. Thus, Sweden has an alarmingly high proportion of motorcyclists killed in barrier accidents (1).

57 motorcyclists have been killed in a barrier collision in Sweden from 2000 to 2014, or nearly four persons per year (Annex 2). 26 riders (45.6 percent) have been killed in barrier accidents on the TENT network (Trans-European transport network). Six accidents occurred on municipal streets and roads. The remaining 25 accidents (44 percent) occurred in the smaller state road. During the same period, 2000-2014, 72 persons in cars were killed in barrier accidents. The risk of a fatal crash with a barrier is significantly higher for those traveling on a motorcycle compared to those traveling in a car. This is the case in all collisions where a motorcyclists is involved and the reason for seeing riders and passengers on motorcycles as vulnerable road users.

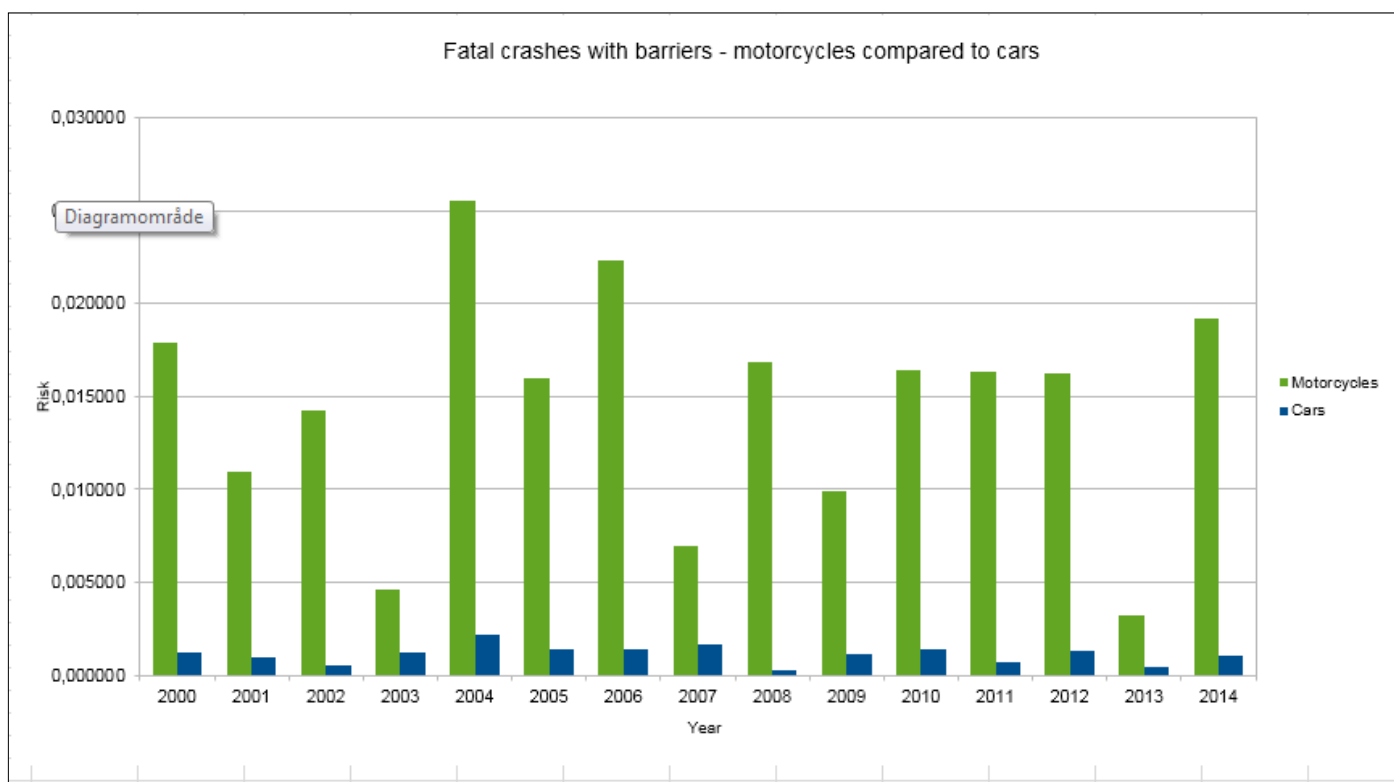

Figure 1. Risk per 1,000 vehicles of being killed in a barrier crash motorcycle/car 2000-2014. **Source:** The in-depth studies of fatal accidents, the Swedish Transport Administration and vehicle fleet SCB June 30 each year.

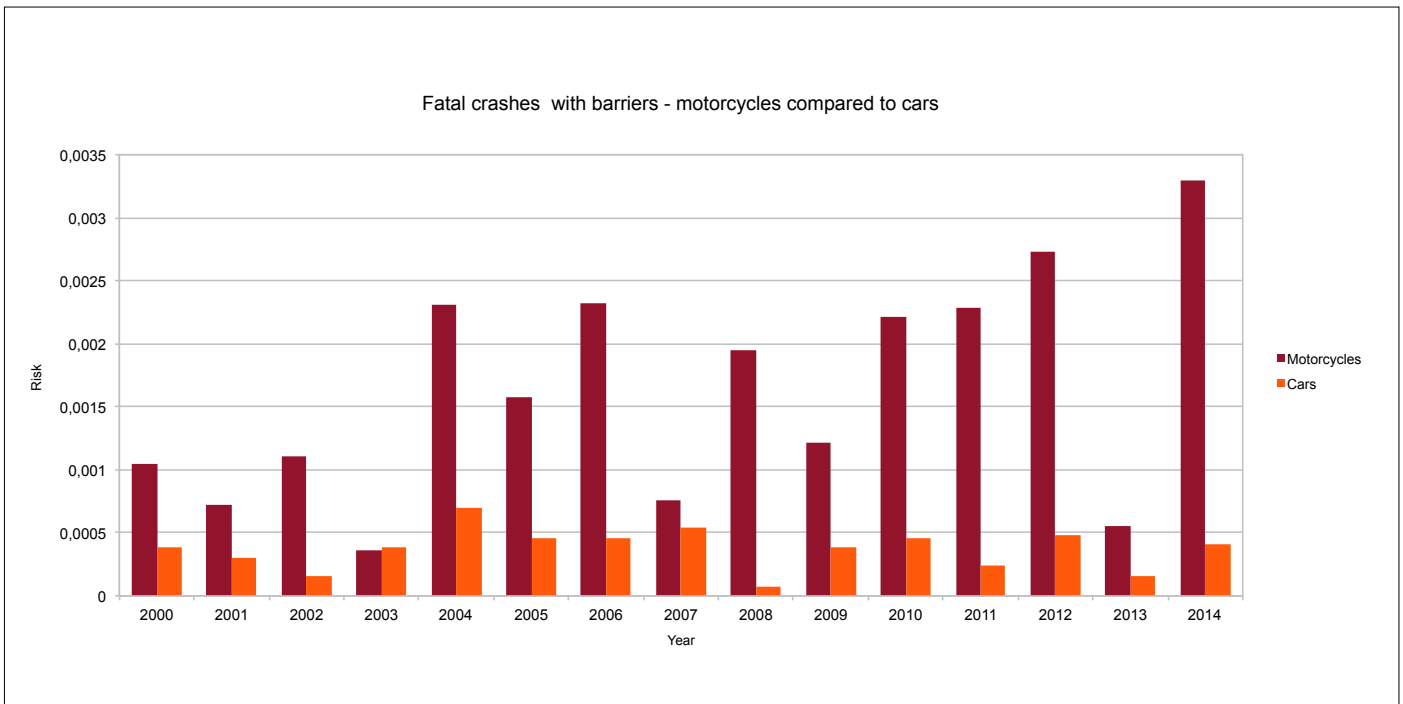
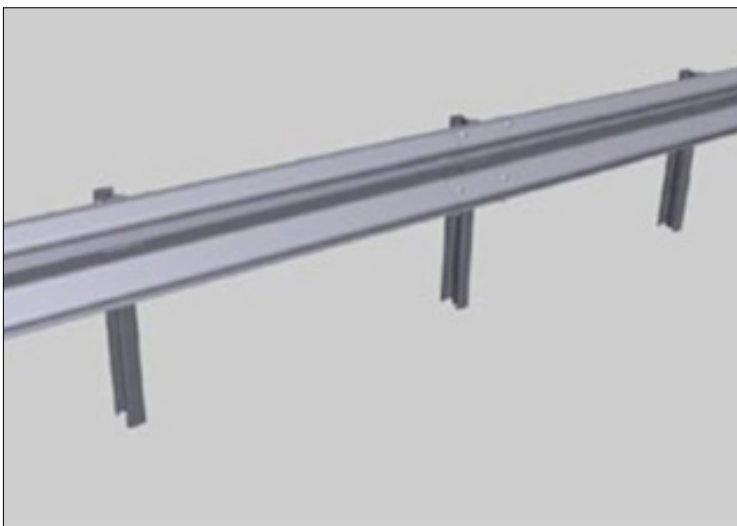

Figure 2: Risk per 1000 km of being killed in a barrier accident motorcycle/ car 2000-2014. **Source:** Swedish Transport Administration in-depth studies of fatal accidents and annual mileage according to Trafikanalys. Mileage for a car estimated for 2014. Mileage MC estimated for 2013-2014.

1.3 Barriers in Sweden

According to the Swedish Transport Administration there were 4000 kilometers of median barriers in Sweden in 2010. The shares were; wire rope barriers 2900 kilometers, 90 kilometers concrete barriers and the rest are pipe- and w-profile barriers. At the same time there were 7000 kilometers of side barriers. The share of side barriers are not known (25). The most common barrier in the world is a w-profile barrier (or A-profile as it is more commonly called) which can look a bit different depending on the country where it is produced.



Picture 1. A w-profile barrier original in Swedish design with sigma posts.

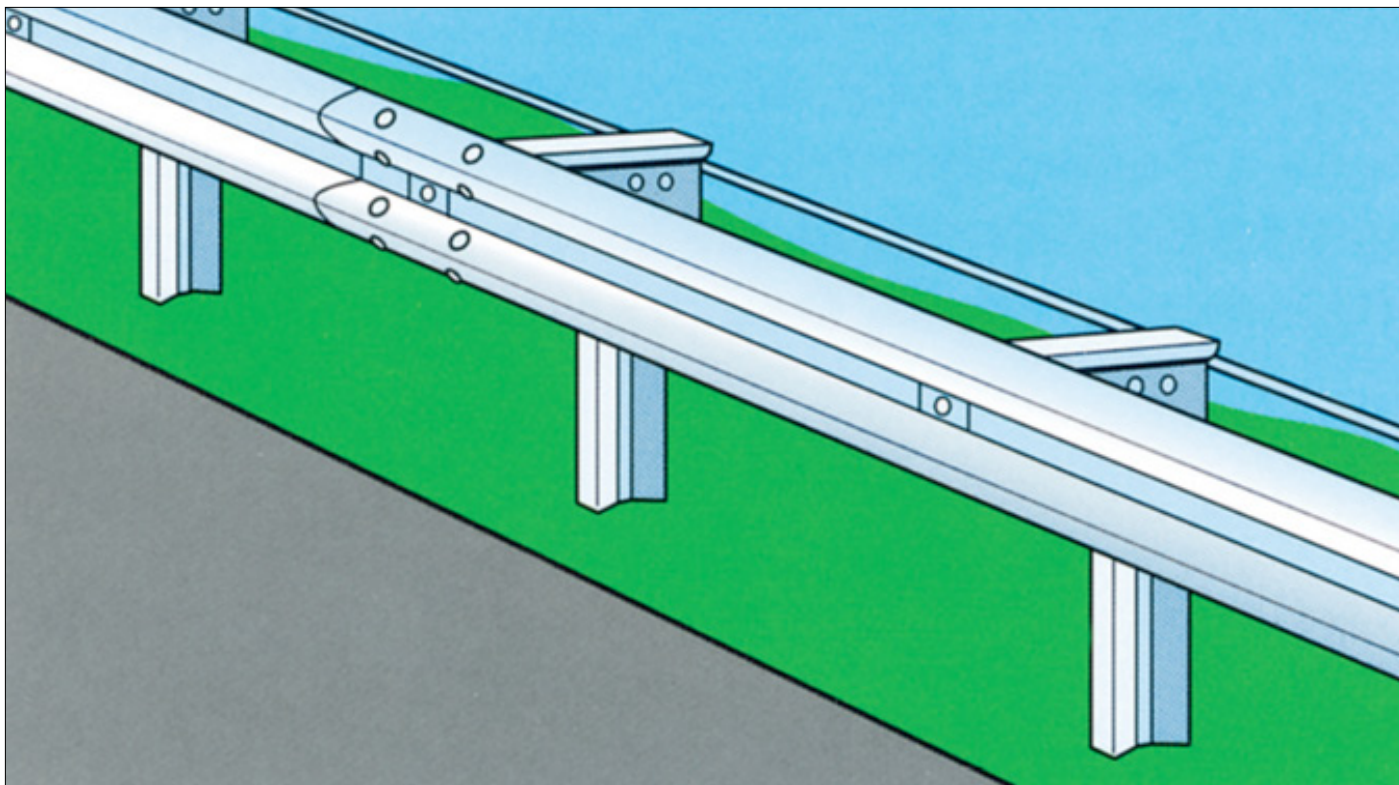

Picture 2. A w-profile barrier of Swedish design with a block-out (barrier name EM2). A w-profile barrier with a block-out gives a chance to install MPS on the poles, providing the distance to the ground is high enough. This is normally not the case on the original w-profile barrier.



Picture 3. W-profile barrier with MPS, installed on an exit of E4 outside Gävle 2014.

1.4 Maintenance

The Swedish Transport Administration has installed MPS protection in 2012 in order to determine their resistance to damage during winter. After two winter seasons, it has not recorded any injury outcomes that would be a hindrance, in terms of longevity and maintenance, installation of this type of protection. There is an accumulation of debris, gravel and leaves on the ground against the side of the road, however, which is an effect that requires some increased maintenance compared with barriers without MPS. The trials will be completed and evaluated after this winter season, becoming the third.



Picture 4. The first barrier with MPS was installed on a road outside Åkersberga May 2012.

CHAPTER 2. TYPE OF INJURIES AND INJURY RISK FOR DIFFERENT TYPES OF BARRIERS

2.1 Myth or truth?

Many studies and presentations from a number of countries, including Sweden, states that it is a myth that cable barriers have a cutting or snagging effect and is usually dismissed as propaganda from motorcycle organizations. This is unfortunately no myth, neither in Sweden nor in other countries. We have taken note of injuries, both in fatal accidents from STRADA and reports from Rescue Services. There are a number of accidents involving motorcyclists who were divided into several parts when they crashed with a barrier (2-3). The same injuries can also be found among the seriously injured.

The cutting and snagging effect applies not only to cable barriers but also guardrails of type W-profile and kohlsua barriers. Wenäll noted in 2011 that autopsy reports described severed body parts, both from cable and steel guardrails (4). The common denominator with cable barriers are a large number of unprotected posts. An Italian study, conducted by two pathologists, contains nasty pictures of mutilated motorcyclist killed in collisions with W-profile barriers. The authors believe that both motorcyclists could have survived if the posts were protected with MPS. The pathologists also adds that their unique knowledge of the injuries from traffic fatalities should be used to create safer roads (5). In general it is the poles, not the longitudinal barrier, that causes the most serious injuries on the motorcyclist.

2.2 Age

Motorcyclists are getting older, the Swedish motorcycle owner is on average 53 years (6) which increases the risk of serious injuries and fatalities in collisions with various obstacles on the side of the roads since older persons are more fragile (7).

2.3 Studies from different countries

2.3.1 Sweden

Two Swedish studies have looked at injuries to motorcyclists who collided with a motorcyclist. The first studied about 20 typical accidents against various barrier types. In almost all accidents, the rider was sitting on the motorcycle at the

collision. Most common were injuries on legs and feet. In the fatal accidents dominated head, neck, chest and pelvis injuries. In the most severe accidents, limbs were torn off. In all the accidents where the motorcyclist died, he/she got caught in the barrier (4).

Another Swedish study has analyzed all police-reported motorcycle accidents with guardrails and made a number of in-depth interviews. Accidents on cable barriers, W-profile and kohlswa barriers have been studied (73 percent of all accidents), while accidents with concrete, pipes and unknown types were removed. The study covers 116 police-reported accidents and 55 interviews.

FSI ratio (Fatal Serious Injury) showed no difference in injury outcomes of motorcyclist collisions with any of the investigated barrier types: cable, w-profile and kohlswa. Meanwhile, the FSI ratio is high, 50 percent or more, in a crash between a motorcyclist and the three investigated barrier types. The FSI ratio is about 35 percent in general motorcycle accidents in Sweden.

The analysis also shows a clear association with risk of injury based on if the motorcyclist was sitting on the motorcycle at the collision or slid into the barrier. Motorcyclists who slipped into the barrier was injured considerably more serious than those who sat on the motorcycle in the collision. The predominant injuries were legs, especially among those who sat on the motorcycle in the collision. The author says that the risk of medical disability and severe outcome can be reduced (8).

2.3.2 Australia and New Zealand

In Australia and New Zealand, a number of studies have been made of 78 fatal accidents on three barrier types: cable, w-profile and concrete. The injuries that occurred was similar, regardless of barrier. Most injuries occurred to the chest, followed by head injuries. More injuries occurred to the chest and pelvis when the motorcyclist slid along the barrier. All riders who collided with cable barrier (seven accidents) had thoracic injuries (1). A previous study by the authors show that collisions with concrete barriers could possibly result in fewer serious injuries (9).

A study was presented in December 2014, based on the 78 accidents in Australia and New Zealand by the authors of the studies above. It constitutes the completion of seven years of research with the aim to clarify which barriers are safer for motorcyclists, where they should be installed and also proposes a new test method. The study concludes that smooth barriers (steel guardrails with MPS and concrete barriers) provides a significantly lower risk of injury to motorcyclists. The best effect is a guardrail with MPS which is envisaged to prevent serious head, neck and chest injuries in collisions at 15 degree angles at speeds up to 100 km/h. Concrete barriers are expected to prevent serious injuries in collisions at speeds below 80 km/h depending on the collision angle (10).

2.3.3 Germany

A German study 2005 compared the crash tests with both a seated dummy on motorcycle (60 km/h) as a sliding dummy against concrete, W-profile and guardrails with MPS. Measurements were made of the collision, both with the barrier and with the ground. This was compared with computer simulations of the seated dummy, which collided with cable barriers at Monash University in Australia. It is the only crash test between a motorcycle and cable barriers that the authors found. No country or manufacturer has conducted or published crash tests with motorcycles and cable barriers in reality.

When the motorcycle and seated dummy collided with the w-beam barrier, serious but not life-threatening injuries when the dummy got stuck and injured by protruding parts. Most injuries occurred on chest, shoulder and pelvis. A corresponding test with concrete barrier gave less damage, but the dummy was thrown over the barrier. The crash tests against w-beam barrier where the dummy and motorcycle slid into the barrier showed very serious injuries over the limit for survival when the dummy collided with a pole after five meters. In the horizontal test against the concrete barrier the dummy slid longer compared to the w-beam. This test also showed injuries that could cause serious or fatal head injuries while injuries to the thorax and pelvis were lower compared with the W-beam barrier.

The German tests provided a basis for a computer simulation in MADYMO model against cable barriers and concrete barrier where the rider drives into the barrier seated at two different speeds and angles. The simulations with concrete barrier showed severe injury to the head and chest, within the limit of survival. The simulations with cable barriers showed very serious injuries, regardless of the speed and angle. In all simulations, the rider got stuck in cable barrier which caught the front wheel in the post and threw the rider forward with the head first. Since the rider got his leg stuck in the cable, the head and chest was hit in the rotating motorcycle. In all simulations the rider was thrown over the barrier with the head first, which meant head injuries that are impossible to survive. Although the risk of getting caught and getting leg snagged was severe in the cable barrier tests, the authors considered that the biggest risk is that the cable led the motorcycle into the posts where the front wheel got stuck and the rider was thrown from the vehicle. No simulations were made when the motorcyclist slid on the ground into the cable barrier.

The study showed that the lowest risk of injuries, in both sitting and lying collisions, was with guardrails with MPS. The MPS made it impossible for body parts to get stuck in the barrier at the seated test. The dummy however, fell over the barrier at the end of the test. The only barrier where a sliding dummy were measured to survivable injuries was in the test with MPS railing (11).

2.3.4 USA

Several researchers in USA have analyzed in-depth studies of fatal accidents on motorcycles. We have not found any study that describes injuries associated with barrier collisions, but a number that describes the risk of injury due to barrier types and other obstacles.

Gabler has studied fatal accidents on motorcycles in several reports 2007-2013 in the United States and 2000-2008. He concluded the one of eight motorcyclists who collided with a railing died. It gives a mortality risk that is 80 times higher compared to those traveling in a car. All studies show a comparable level of risk based on two compared barrier types: steel guardrails, w-profile and concrete barriers. All collisions with fixed objects leads to higher risk of death compared with the risk of colliding with another vehicle or a fall to the ground. The risk of being killed in collision with w-profile barrier is 12 percent, while the risk of being killed in collision with concrete barrier is 8 percent. Gabler concludes that the risk of serious injury is 1.4 times higher in crash with w-profile compared with concrete railing. The study found no significant difference in collision with a cable barrier compared to the w-profile barrier. Gabler has also found that the risk of death is higher in collision with both concrete and w-profile rail compared to cars where the risk is 4.8 per cent (12, 13, 14).

2.3 5 Malaysia

Computer simulations were carried out at different speeds, different angles and with different distances between the posts. It contained only simulations against w-profile barriers which are the most common barrier type on the particular motorcycle roads in the country. The study concludes that W-profile barriers are not safe for motorcyclists and the risk of serious injury increases with higher speed, higher impact and the shorter the distance between the posts (15).

CHAPTER 3. ACCIDENT SEQUENCE

Regardless of the study and the country in which research is conducted, the results show that in about half of the accidents the motorcyclist was sitting on the motorcycle at the collision, in half the motorcyclist was sliding into the barrier. When the motorcyclist is sitting on the motorcycle, the risk that the driver is thrown over the barrier is relatively high. The risk of being thrown over the barrier seems to be similar for w-profile and concrete barriers. Simulation studies made with collisions against cable barriers showed that the rider always was thrown over the barrier (11). The majority of the investigated accidents in all countries takes place at angles less than 15 degrees, while the European technical specification TS 1317-8 uses 30 degrees at the test.

3.1 Sweden

The Swedish study of 160 accidents showed that the impact angle was 1-20 degrees in 50 percent of accidents. 29 percent of all riders slid into the barrier, 23 percent were sitting on the motorcycle and fell over the barrier, 36 percent were sitting on the bike and did not fall over the barrier, and in 13 percent, the circumstances of the accident is unknown. An analysis of the fatalities in the Swedish study showed that 43 percent slipped into the barrier, 32 percent were sitting on the motorcycle and fell over the barrier and 25 percent were sitting on the motorcycle without falling over the barrier (16).

3.2 Australia and New Zealand

Out of the 78 surveyed fatalities in Australia, the average angle was 15.4 degrees and the average speed was 100.8 km/h. The distance from impact to stop was 28.9 meters for a seated motorcyclist, 26.3 meters when the motorcyclist scraped, rolled or slid along the railing top and 12.7 meters for the motorcyclist who slid along the ground (1).

3.3 Germany, the Netherlands, France, UK and Finland

The project APROSYS analyzed motorcycle accidents in four databases. It notes that most accidents occur at low angles at a speed of 50 km/h. It is more common that the motorcyclist is sitting on the motorcycle at the collision than the rider/passenger sliding into the barrier or other obstacles in the side area (17).

3.4 UK

In depth studies of motorcycle accidents in England and Wales showed that in 47 percent of the accidents the rider was sitting on the motorcycle, in 37 percent the rider was sliding on the road prior to the collision. Four percent rolled and 12 percent fell over the barrier (26).

CHAPTER 4. WHERE DO THE ACCIDENTS OCCUR?

4.1 Sweden

A review of 57 Swedish fatalities among motorcyclists and motorcyclist from 2000 to 2014 shows that 26 of the accidents occurred on the TENT-network (18). 53 percent of all barrier accidents in STRADA 2003-2010 took place on collision-free roads without oncoming traffic. Two thirds of the accidents occurred on a curve, the rest on a straight road. 39 percent of the accidents occurred on roads with a maximum speed of 90 km/h or more, while 48 percent took place on 50 and 70 routes.

The Swedish study of 160 accidents conducted by Vectura and the Swedish Transport Administration identifies two types of rail accidents in Sweden:

1. Accidents on busy roads with high standards and high speed limit. No significant differences in risk of injuries between different W-profile barriers and cable barriers were found.
2. Accidents on smaller roads with low standard. 20% higher risk of injury in a collision with barriers compared to other single vehicle accidents where rider went off the road (16).

4.2 Australia and New Zealand

Accident analysis of all barrier accidents in New Zealand shows that twelve of the 20 accidents occurred on State highways with 100 as a speed limit. Fifteen of the fatalities occurred in the curve. Of accidents with non-fatal outcome, 83 percent occurred in a curve. Countries with guidelines for installation of MPS has demands for MPS in curves with a given radius and at slip roads. A brand new study from Australia/NZ notes that it is economically viable to install MPS along roads with a lot of motorcycle traffic (10). Germany has implemented similar initiatives combined with other measures in the road environment in Euskirchen which has resulted in fewer fatalities in motorcycle against barriers but more significant in a larger amount of seriously injured (19).

4.3 UK

A study of all police reported accidents in England, Scotland and Wales between 1992 and 2005 showed that a majority of the accidents with median barriers occurred on roads with high speed, 70 m/p h or 112 km/h. When looking at only the fatalities the shares are divided like this: 38,5 percent of the fatalities occurred on a straight road, 32 percent in a left hand bend and 19,1 percent in a right hand bend. 6,1 percent occurred on exits or entrances and 3,2 percent in a roundabout.

4.4 The installation of barriers

The Swedish study of a number of typical motorcycle accidents against different types of barriers drew attention to the importance of a recovery zone. A recovery zone allows the rider to take evasive action if something unexpected happens on the road. It is obvious that increased barrier expansion close to the roadway gives more barrier collisions for all types of vehicles (4).

The Swedish regulation for installation of Vehicle Restraint Systems, VRS, in the road environment is "Vägar och Gators Utformning, VGU". According to VGU it is allowed to install a median barrier 0,35 meters from the roadway. A side barrier should be installed 5 centimeters from the paved edge of the road. This is a very limited area for recovery if anything unexpected happens.

An American study based on accidents in Indiana describes which barriers have the best effect for accident reduction and at what distance from the road they should be installed. The study describes demands from different states in USA for median and barriers. Most states requires a median strip of 40-70 feet (12-21 meter). Based on the different distances between the road and the barrier the study gives recommendations on choice of barrier: concrete, wire or w-profile barriers(27).

Research is also available in this area which shows that increasing the distance of both barriers and other fixed obstacles in the road environment provides improved security. Several studies describe that higher demands on the roadway and roadside width increase safety. IRAP has presented a number of guidelines regarding the installation of obstacles in the road lane areas. The guidelines are based on iRAPs methodology to identify safe routes. ARRB Group has also evaluated iRAPs risk parameters. ARRB say that a very important factor for determining the risk of collision is road width, including paved shoulders. The risk decreases by increasing both the road and the coated roadside width. Several studies describe how the accident risk decreases by increasing the roadside width of 1,5-2,5 meters (20). Norwegian "Trafikksikkerhetshåndboken" points to the same accident reduction with increased width of the shoulder (21).

iRAPs guideline "Roadside Severity Distance" concludes that most collisions with obstacles in the road environment occurs in 5-20 degrees. The relatively low angle means that recovery zones up to five meters or less can have an effect on the outcome of the accident. A number of studies are analyzed and all clearly show that an increased security zone

from one to five meters would increase safety substantially, both for those who travel in cars and on motorcycles (22). The same results are reported in the Norwegian Trafikksikkerhetshåndboken (21).

CHAPTER 5.

5.1 Conclusions

- All studies point in the same direction regarding accident sequence, injury risk and injuries. Based on accident data and simulations, we have based our definition of a safe barrier for motorcyclists. First, some certainties that are important to point out regarding barriers.
- If the barrier itself is more dangerous than what the barrier is designed to protect from - no barrier should be installed.
- The more barriers that are installed without MPS, the more motorcyclists will be killed and seriously injured in barrier accidents.
- The risk of injury to a motorcyclist who collides with a barrier is very high compared to those traveling in the car.
- The main task for the median barriers is to reduce the risk of collisions, which will benefit all road user groups. But the median barriers must also include a minimal risk of injury for those who collide with them, also vulnerable road users like motorcyclists.
- A gentle slope or a ditch without a fixed obstacle means significantly reduced risk of injury to a motorcyclist compared to a side barrier.
- Barrier types with unprotected poles; w-profile, kohlswa- and cable barriers have the highest risk of injury to motorcyclists. Uneven top with accessible pole tops increase the risk of serious injuries.
- Barrier types with MPS have the lowest risk of injury to motorcyclists, regardless of how the collision occurs.
- Most Swedish fatal accidents on motorcycles occurs in curves, also among the barrier accidents. The risk of being injured and killed in rail accidents is very high on TENT roads.
- A wider recovery zone, between barriers and road reduces both the risk of accidents and the risk of injuries.
- Guardrails where body parts may get stuck is worse than barriers where body parts can slide along the barrier.
- A motorcycle-friendly barrier shall not impair the safety of those traveling in cars or other types of vehicles.
- The road authorities can reduce the risk of injury to motorcyclists in the selection of the roadside measurements, the choice of barrier and the distance between barrier and roadway.

A safe barrier for motorcyclists is

- a barrier where you cannot be thrown over in a collision
- a barrier without protruding parts where parts of the body and/or the motorcycle can get caught
- a barrier without openings, vertical or horizontal, where parts of the body and/or the motorcycle can become trapped
- a barrier with a smooth upper surface
- a barrier without unprotected posts in both the ground level and the top side
- a barrier with energy-absorbing MPS
- a barrier that is not fitted with attachments which involve a higher risk of injury and
- a barrier which is located at a distance from the road surface allowing a rescue space

5.2 Classification of barriers, based on collision-friendly features

Based on the literature review, we have made a proposal for a classification of barriers, based on collision-friendly features when a motorcyclist, sitting or sliding, collides with a barrier. The classification is done from -1 to +5 where the 0 level is represented by the most common barrier in the world, the w-profile barrier. For each step upwards, positive barrier properties that reduce the injury risk are added. They are specified after the characters **, each of which reduces the risk of injury. In each class there are specified examples of typical barriers in the class. Pictures of each type of barrier are shown in Appendix 3.

Class	Positive barrier properties	Examples of typical barriers
5 **	** Smooth side with energy-absorbing MPS, smooth top, overrun protection fitted	Non existing
4	Overrun possible ** smooth barrier profile, energy absorbing MPS smooth top	Euskirchen Plus
3	Uneven top, top of post accessible, overrun possible, ** smooth barrier profile, energy-absorbing MPS	W-beam with MPS according to TS 1317-8
2	Uneven upper surface, overrun possible ** smooth barrier profile, existing MPS function with smooth side but not energy-absorbing, no unprotected poles	Concrete barriers
1	Accessible posts cc <4 m, sharp edges, large openings in horizontal and vertical directions, overrun possible ** smooth barrier profile with smooth / dividing box beam guard rail (“roofed W-beam”) with smooth steel profile both side and top	“roofed W-beam” with smooth profile on both side and top
0	Accessible posts cc <4 m, sharp edges, large openings in horizontal and vertical directions, uneven top, overrun possible ** smooth barrier profile	W-beam, kohlsua
-1	Protruding parts on the barrier side and top, accessible posts cc <4 m, sharp edges, large openings in horizontal and vertical directions, uneven side and top, overrun possible	Cable barriers with supporting hooks

Definitions:

Sharp edges implies a radius less than 40 mm (tubular barriers typical diameter of about 90 mm)

Protruding parts may be hanging devices for rope, screw heads which are not rounded, steel edges and pole tops sticking out above the barrier

Large openings are those in which a body part can enter, get caught or slide through

Uneven side constitutes that part of the barrier that serves as railing (capture/hold back the vehicle) is not smooth. In addition to an increased risk of injury when sliding along the barrier, the wheel on the motorcycle can get stuck as well as the foot pegs and body parts.

Uneven top means that the post tops are accessible, ends flush with or less than 50 mm below the top edge of the railing, alternatively the railing design is uneven for other reasons, such as joints between concrete elements.

A longer distance between the posts is supposed to increase the chance for a sliding rider or passenger of a motorcycle to slide between the posts without touching them. If the angle is narrow, the collision speed will most likely be reduced before the collision. Four meters between the poles is a typical max distance on a w-profile barrier and is thus seen as a “norm”. A barrier where the posts are placed with a longer spacing than four meters can be seen as a reason for upgrading the barrier to a higher level in the classification scheme.

The possibility of retrofitting and adding MPS to existing guardrails to make the barrier more MC-friendly is a positive quality that is not valued above.

The distance from the roadside/outer coating and barriers are not taken into account since this is a factor that is assumed to limit the risk of collision, the greater the distance is. It is a positive effect but it is not a quality in the barrier itself. The table above instead assumes that a collision occurs and how the injury risk can be minimized when it happens.

CHAPTER 6.0. DISCUSSION AND SUGGESTIONS FOR ACTION

6.1 Safer barriers

There is a huge difference between different countries when it comes to the type of barriers that are installed, in what extent MPS is installed and what distance is seen as a safe zone between the barrier and the road. This is important to have in mind when comparing international research.

An increased use of barriers in Class 3-4-5 above instead of -1 and 0 would reduce the risk of injury among motorcyclists significantly. Road authorities should endeavor to always choose barriers where the retrofitting of MPS protection can be used to increase motorcycle safety.

It would be possible to do the w-profile barriers safer by using a block-outs on the railing but not on the MPS. This will

avoid that the foot peg and legs to collide with the MPS protection in a collision. It should also give greater possibility that the motorcyclist will not fall over the barrier. However, at the same time there is a greater risk of hitting the pole tops when a person slides on top of the barrier.

It should be possible to introduce similar regulation in Sweden as in Norway for where MPS should be installed on the road network. Most motorcycle accidents occur in curves and the Norwegian rules are based on crash tests with barriers based on the Vision Zero collision curves (23).

The above proposal does not solve the problem of barrier accidents on the TEN-T road network where there are only requirement of using MPS on side barriers at the exits. Studies from other countries point out that accidents also happens at entrances why MPS should be considered also at entrances. Most barrier accidents on TENT-roads occurs on the straight roads. A first measure is to increase the distance between the roadway and the median and side barriers. The safety zone in the middle of the road is narrow, or almost non-existing, on the roads rebuilt to 2+1-roads in Sweden.

In addition to this, the barriers on the TENT-roads with high speed limits should be chosen with great care. There are existing requirements to use barriers that are safer for unprotected road users (including motorcyclists) at the initial investment and replacement of barriers (24). Although it is desirable that all barriers are fitted with MPS, it is unclear whether this is economically viable. At the workshop in February a barrier producer claimed that MPS can be sold at € 20 per meter if the volumes would increase, Today there is simply no demand from the Swedish Transport Administration.

This is an area where the Swedish Transport Administration could initiate and fund innovative work to find a barrier type that reduces the risk of injury for motorcycle riders while maintaining or even increase the protection for other vehicles. A slightly increased barrier height, about 100 mm for the W-profile barrier in containment level N2 provides better vehicle restraining effect and allows the installation of many existing MPS system. The MPS are often too high to fit between the existing W-profile and ground with the old standard height of 550 mm to the center of the railing. Median and side barriers with smooth and wider railings than what's on the existing railings is desirable. Existing concrete railings could be used to a much greater extent than today since they present a lower risk of injuries to motorcyclists compared to a cable-, w-profile- and kohlsua barriers. However, without initiative, requirements and wishes of road management, there will be no development in this area.

6.2 Safer road sides

It is not difficult to improve safety for motorcyclists regarding roadsides. A first response is to never install side barriers on the roadsides if they can be cleared of obstructions. Another measure is to increase the width of the paved shoulder and also the distance to the side barrier. This will also reduce the injury risk. This calls for clear requirements in all regulations that govern the roads and street design and maintenance.

6.3 Reduce fall over the barriers

One first measure is to demand higher barriers compared to today, for both median and side barriers. Higher barriers have in tests shown positive effects for several road user groups in USA (28-29). Another possible measure to reduce falls over median and side barriers is to trap the motorcyclist safely before the motorcycle and rider reaches the barrier. This could be accomplished by creating sand pits between roadside and road barrier in the same way as in the motorcycle sport.

6.4 Tests and international coalitions

Today's test method in which an MPS protection is tested by a lying dummy which slides with the head first against a barrier is too complicated. This method is costly since the dummy breaks in collisions above 60 km/h. Thus, it is difficult to measure the outcome of the collision. The collision occurs at an angle where few accidents happen, 30 degrees, and also sliding on the road. These accidents are less common compared to collisions with a motorcyclist sitting on the bike at the collision. It is not possible to conclude from the present test if the barrier makes it possible for the rider to fall over the barrier or to get caught on the pole tops of the barrier.

After the workshop the working group got a document from Belgium that shows demands on tests for approval and installation of MPS at new installations where the containment level is H2 or lower or when the containment level is H2 or higher. The document also gives guidelines for retrofitting and completion of MPS on existing barriers. Examples are given on acceptable solutions on barrier type, attachment and what happens when the MPS protection is installed.

The present test method TS1317-8 is a translation of the Spanish method UNE135900, which is based on an early French method developed by Lier in France. The method appears to be authoritative with a dummy, dressed in motorcycle gear, is thrown in the barrier with head first. The test is only focusing on motorcyclists who have fallen off the bike and slides on the road into the barrier. There is no motorcycle involved in the test at all. The dummy is developed for tests of seat belts and airbags in cars. The dummy is wearing a helmet beside the motorcycle gear. There is a risk that the choice of helmet can have an outcome of the test, depending on the choice of helmet. There are however no doubts that the MPS

systems that have been approved according to the test have saved lives and reduced injuries on motorcyclists who have crashed with the MPS system, both sitting on the motorcycle and sliding on the road when colliding with the barrier.

Few researchers have knowledge of what a human being can survive at a collision which is the reason for creating a test method the opposite way. If you first define what you want a safe barrier for a motorcyclist to do with the bike and the rider and what parameters that differs between a good and a bad barrier, you can design tests or demands focusing on those parameters. For example one can say that sharp metal edges are dangerous and thus describe minimum radius or that sharp edges should not be able to reach with a spherical dummy.

The dummy itself is a random scourge and could be replaced by a rubber lump with a cylindrical form. The rubber lump can give objective and repeatable measurements, regardless of angle or trajectory.

The helmet effects the test and should be replaced by a steel sphere, a steel ball which can be instrumented. To a technician a steel sphere is something that is repeatable and can give an objective result of the barrier properties, regardless of the quality of the helmet. Test methods is about creating repeatable conditions that can be interpreted. To us it is obvious that the TS 1317-8 should be revised as soon as possible and replaced with a standard for MPS.

6.5 Open standard

Sweden could create an open standard considering MPS that could also be possible to use on an international level.

An open standard allows interoperability between products of different makes that follows the standard and free competition between producers and engineers of these products. The possibility of creating an open standard and if the open standard can be used instead of the present technical specification should be investigated by the stakeholders taking part in the standardization work.

6.6 Dissemination of the result

The final report will be sent to the Swedish Transport Administration for a approval. It will be sent out to our network in the Swedish Transport Administration and the Swedish Association of Local Authorities and Regions who are the major street and road owners in Sweden where motorcycle accidents with barriers occurs and also in charge of the regulation for barriers in Sweden. The report will be spread to the insurance companies since they pay for the damage on both barriers and persons in these accidents. The Swedish Police force and the Rescue teams will receive the report since they are involved at the accident scenes. Politicians at different levels will get the report as well as the ministry of Transport in Sweden. It will be sent to all barrier producers in Sweden and ERF, European Road Federation in Europe. It will be sent to SIS and CEN – the Swedish and European Standardisation bodies. The websites of SMC, SVBRF and VTI will be used to launch the study as well as social media, membership magazines and other media. The study is translated to English in order to be used with our international partners.

References

1. Motorcyclist impact into roadside barriers, Grzebieta et al 2013
2. STRADA motorcycle accidents against barriers 2005-2014
3. Reports from Rescue Services in connection with fatal accidents with MC / railing
4. Motorcyclists colliding with crash barriers, Study of a number of typical accidents, Wenäll 2011
5. Massive Lesions Owing to Motorcyclist Impact Against Guard Rail Posts: Analysis of Two Cases and Safety Considerations, Brandimarti et al 2011.
6. The Swedish Transport Agency, Traffic Registry in 2014
7. Probabilistic Models of motorcyclists' injury severities in single- and multi-vehicle crashes, Savolainen et al 2006.
8. Motorcycle Crashes into Road Barriers: The Role of Stability and Different Types of Barriers for Injury Outcome, Rizzi et al, 2012
9. The Protective Effect of roadside barriers for motorcyclists, Bambach et al 2012
10. Motorcycle crashes into roadside barriers, Stage 4: Protecting motorcyclists in collisions with roadside barriers, Bambach & Grzebieta, 2014
11. Motorcycle impacts to roadside barriers - real world accident studies, crash tests and simulations Carried out in Germany and Australia. Berg et al 2005
12. The risk of fatality in motorcycle crashes with roadside barriers, Paper 07-0474, Hampton C. Gabler 2007
13. The emerging risk of fatal motorcycle crashes with guardrails, Hampton Gabler 2007

14. Fatality risk in motorcycle collisions with roadside objects in the United States, Daniello & Gabler 2010
15. Roadside barrier and passive safety for motorcyclists, Ibitoye et al 2007
16. Motorcycle accidents in the railing, Vectura / Transport Administration in 2011, presentation. Analysis of 160 rail accidents and 55 in-depth interviews.
17. Technical bases for the development of a test standard for impacts of powered two-wheelers on roadside barriers, Peldschus et al 2007
18. Crash barrier collisions, The Swedish Transport Administration in-depth studies of fatal accidents from 2000 to 2014
19. Merkblatt zur Verbesserung der Verkehrssicherheit auf Motorradstrecken, 2007
20. Review of IRAP risk parameter, Turner et al ARRB Group, 2009.
21. Trafikksikkerhetshåndboken, Elvik et al Institute of Transport Economics, 2012
22. IRAP Road Attribute risk factors; Roadside severity-distance, 2013
23. Rekkverk och vegens sidoområder, Chapter 3.8, Norwegian Public Roads Administration in 2014. 24. Road Safety Act (2010: 1362) and TSFS 2010: 183rd
25. Inriktning för väg- och broväg, Trafikverket TRV 2010/98486
26. Safety barriers and motorcyclists, G L Williams et al, 2008 TRL
27. Effectiveness of cable barriers, guardrails, and concrete barrier walls in reducing the risk of injury, Yaotian Zou et al 2014
28. Midwest guardrail system for standard and special applications, Bielenberg et al 2012
29. Development of the Midwest Guardrail System, Reid et al, 2002
30. The Swedish Transport Administration website, contact Hans Holmén

Appendix 1. Studies and research in the field and method

Appendix 2. Fatal motorcycle- barrier accidents Sweden 2000-2014

Appendix 3: Examples of barriers in each class.

Bilaga 4. Rapport från workshop 20 februari i Sollentuna.

APPENDIX 1. STUDIES AND RESEARCH IN THE FIELD AND METHOD

Sweden

Motorcycle Safety - a literature review and meta-analysis, Pål Ulleberg 2003. Method: literature review.

VTI notat 38-2002, Motorcycles and crash barriers, Göran Nilsson. Method: Literature study and review of motorcycle accidents against barriers.

VTI notat 43-2005, Crash barriers and hazards to motorcyclists in collisions with a small angle, Håkan Andersson 2005. Method: Literature study of collisions with low collision angle to the road barrier, less than 20 °.

Motorcyclists colliding with crash barriers, Study of a number type accidents, Jan Wenäll 2011. Method: By calling for accidents from the Police, SMC and the Swedish Transport Administration examine the typical personal injury as a motorcyclist hit by the collision with a crash barrier, with a hope to be able to link the injuries to specific technical details and, if possible, identify possible improvements in barriers.

Motorcycle Crashes into Road Barriers: The Role of Stability and Different Types of Barriers for Injury Outcome, Rizzi others. Method: an analysis of police-reported accidents and in-depth interviews with a number of motorcyclists who collided with railings. Both analyzes compared the motorcyclists injuries.

Improved road design for future maintenance - Analysis of Road Barrier Repair costs. Hawzheen Karim 2011. Method: Treatise on the rack-life costs, including social costs, as well as injury rate per edge protection based on the cost of railing repairs and accidents in STRADA.

Motorcycle accidents with barriers, Vectura/the Swedish Transport Administration 2011, presentation. Analysis of 160 rail accidents and 55 in-depth interviews.

Norway

Trafikksikkerhetshåndboken, Alena Høye, Rune Elvik, Michael WJ Sørensen, Truls Vaa, Institute of Transport Economics in 2012. Methods: A comprehensive literature review concludes with suggestions. Describes, among other things, risks of side barriers compared with forgiving roadside areas and how the road's width and increased recovery zone can reduce the risk of accidents.

Rekkverk och vegens sidoområder, Public Roads Administration in 2014. Chapter 3.98 describes requirements on the railings outside the MC safety, and in which curves, based on speed and radius, railing protection to be installed.

Crash tests Nordic Test Center AS 2009, dummy against barrier with MPS protection (STAR MC Hallingplast AS). Objective: The approval of the MPS for the Norwegian market.

Italy

Massive Lesions Owing to Motorcyclist Impact Against Guard Rail Posts: Analysis of Two Cases and Safety Considerations, Brandi Marti multi 2011. Methodology: autopsy of two killed MC drivers against the railing with W-beam.

Germany

Schutzeinrichtungen am Fahrbahnrand kritischer Streckenabschnitte für Motorradfahrer, Jürgen Gerlach and Kai Oderwald, Heft 152 BAST 2007. Methodology: analysis of accidents in Rhineland-Pfalz. Analysis of road conditions where accidents occurred which were compared with distances without accidents. The booklet presents suggestions on where planners should consider measures MPS to reduce the risk of injury to motorcyclists.

Pruefung von Fahrzeug-Rückhaltesystemen an Straßen durch Anprallversuche Gemäß DIN EN 131, Heft 157, Ralf Klöckner and Jürgen Fleisch, BAST 2007. Method: The study deals with barriers and MPS that reduce the risk of injury for both heavy traffic and motorcyclists. The results will be used to develop a barrier standard.

Anprallversuche an motorradfahrerfreundlichen Schutzeinrichtungen, Heft 193, Ralf Klöckner, BAST 2010. Describes how the MPS developed to railings will be safer for both those who travel in cars and on motorcycles. A new railing protection, "EDSP-Motorrad" was designed based on research and experiences from the Federal Highway Research Institute.

Merkblatt zur Verbesserung der Verkehrssicherheit auf Motorradstrecken, 2007. An MC-working group of the "Gesellschaft für Forschung und Straßen-Verkehrswesen" has studied motorcycle accidents, implemented measures and then presented a paper on how popular motorcycle roads can be made safer.

Germany/Australia

Motorcycle impacts to roadside barriers - real world accident studies, crash tests and simulations carried out in Germany and Australia. Berg & Grzebieta 2005. Method: Step 1 in Germany: Analysis of 57 motorcycle accidents leading to two different test scenarios (seated 12 ° / sliding 25 °) in 60 km / h on W-beam and concrete railings. Although tests against railing with MPS. Step 2 at Monash University, Australia. The German performance against the concrete railing was used for computer simulation for motorcycle drivers who collide with railing sitting on motorbike. The model has been used for different speeds in the 25 ° angle with the cable barrier.

Skottland

Safety barriers and motorcyclists, G L Williams et al, 2008 TRL. Method: literature study, a pan-European questionnaire, in depth studies of accidents and the barriers in use in England, Wales and Scotland. Special focus on cable barriers.

Spain

Improving motorcyclists' safety in Spain by Enhanced Crash Test Procedures and Implementation Guidelines, Garcia and others 2009. Methodology: evaluation and development of Spanish test method UNE 135900-2008.

Innovative Concepts for Smart Road Restraint Systems (RRS) to Provide Greater Safety for motorcyclists, Juan Albla multi 2014. Methodology: a part of the project Smart RSS, which includes testing of the railing with sensors that function as e-call.

Technical bases for the development of a test standard for impacts of powered two-wheelers on roadside barriers, Stefan Peldschus et al 2007. Metho: 1000 analyzed in depth studies in various European databases and investigated the railing collisions. Also investigated methods of testing in Spain and Germany.

USA

Probabilistic models of motorcyclists' injury severities in single- and multi-vehicle crashes, Savolainen, Mannering 2006. Method: Investigated all police-reported motorcycle accidents in Indiana 2003-2005.

Death by Motorcycle: Background, Behavioral and Situational Correlates of Fatal Motorcycle Collisions, Samuel Nunn 2011. Method: Analysis of 601 police-reported fatalities from 2003 to 2008 on the motorcycle in Indiana, USA. Order to identify the causes of death and the factors that increase the risk of being killed.

The risk of fatality in motorcycle crashes with roadside barriers, Paper 07-0474, Hampton C. Gabler 2007. Method: Analysis of several different reporting of accidents and vehicles.

The Fatal and Serious Injury Risk of Motorcycle Collisions with Traffic Barriers, Hampton Clay Gabler, 2014. Presentation at the International Road Federation-Asia Conference Designing Safer Road Side.

The emerging risk of fatal motorcycle crashes with guardrails, Hampton Gabler 2007. Methodology: Comparative analysis of rail accidents in the US for motorcycle and car.

Fatality risk in motorcycle collisions with roadside objects in the United States, Allison Daniello, Hampton C. Gabler, 2010. Methodology: analysis of two databases Motorcycle accidents from 2004 to 2008. The aim is to clarify the risk of being killed in a collision with different object.

Characteristics of injuries in motorcycle-to-barrier collisions in Maryland, Allison Daniello and Hampton C. Gabler 2012. Method: investigated 1707 accidents among motorcyclists in Maryland 2006-2008 in order to compare collisions with barriers with three other types of motorcycle accidents and collisions.

Effectiveness of cable barriers, guardrails and concrete barrier walls in reducing the risk of injury, Yaotian Zou et al, 2014. Method: Investigated 481 roads with three different types of barriers in Indiana to find the injury reducing effects.

Malaysia

Roadside barrier and passive safety for motorcyclists, Ibitoye, Radin, Hamouda 2007 Method: Simulations MADYMO W-profile. Different angles (15,30,45) different speeds (32, 48, 60) and the varying distance between the poles (2 and 4 meters).

Australia/New Zealand

Motorcycle crashes into roadside barriers, Stage 4: Protecting motorcyclists in collisions with roadside barriers, Bambach & Grzebieta, 2014. Method: A fourth and final step in the research on collisions MC railings with a view to provide knowledge about how railings can be made safer for motorcyclists without increasing the risk to other road users. Analysis of 78 fatalities in Australia / New Zealand and a number of simulations. Motorcycle impact into roadside barriers, Grzebieta, Bambach, McIntosh, 2013. Method: Has studied 78 fatal accidents motorcyclist-railing (2001-2006) in Australia / NZ on cable barriers, W-balk and concrete.

Motorcyclist Impacts Into Roadside Barriers- Is the European Crash Test Standard Comprehensive Enough? Raphael Grzebieta, Mike Bambach, and Andrew McIntosh 2013. Method: Have compared the European technical specification EN 1317-8 for motorcyclists who collide with railings and relevance for Australian fatal accidents where the motorcyclist collided with railings.

The Protective Effect of roadside barriers for motorcyclists, Bambach, Mitchell, Grzebieta, 2012. Method: Analyzed police reports and hospital data in 1364 cases from 2000 to 2009 and compared railing collisions with obstacles. Seven collisions with cable barriers were removed from the study, because of the low number.

Injury Typology of fatal motorcycle collisions with roadside barriers in Australia and New Zealand in 2011, Bambach, Grzebieta, McIntosh. Method: Analyzed autopsy reports of all fatal accidents MC In Australia and New Zealand, of 1348 were 78 fatal accidents against the railings.

Characteristics of fatal motorcycle crashes into roadside safety barriers in Australia and New Zealand, Jama Hussein, H. 2010. Method: Based on autopsy reports in Australia and New Zealand 2001-2006.

Singapore

An Analysis of Motorcycle Injury and Vehicle Damage Severity using Ordered Probit Models, MA Quddus, 2001. Methodology: Analysis of all motorcycle accidents in Singapore from 1992 to 2000.

EuroRAP

Barriers to Change - Designing safe roads for motorcyclists, EuroRAP 2007. Methodology: a panel of experts from various countries analyzed statistics and research, pointing to the proposed measures.

FEMA

Crash Barrier Report, Eric Thiollier FEMA 2000. Method: A review of existing test methods, railing protection and infrastructure safety railings in Europe. Concludes with proposals for action.

The road to success - reporting of ongoing measures to increase motorcycle safety with respect to the railings in Europe in 2005.

New Standard for Road Restraint Systems - Designing Safer road-side for motorcyclists, 2012. The document is written a FEMA under the project Riderscan where research, statistics and measures from all over Europe were compiled and analyzed.

IRAP

Review of IRAP risk parameter, Turner and others ARRB Group, 2009.

Road Attribute risk factors; Media Type, 2013. Method: iRAPs toolkit and literature studies

IRAP road attriute risk factors; Roadside severity-object, 2013. Method: Literature study iRAPs + toolkit.

IRAP Road Attribute risk factors; Roadside severity-distance, 2013 Method: iRAPs toolkit and literature studies.

APPENDIX 2. FATAL MOTORCYCLE- BARRIER ACCIDENTS SWEDEN 2000-2014

R= rider P= passenger E=transeuropean network roads

Month	Day	County	Place	Road	Road	Age R/P
2014						
4	23	Uppsala	Enköping	Trafikverket	E18	54/R
5	30	Skåne	Åstorp	Trafikverket	E4	42/R
7	5	Ö-götland	Söderköping	Trafikverket	LV799	34/R
7	16	Y	Örnsköldsvik	Trafikverket	E4	49/R
7	24	X	Sandviken	Trafikverket	E16	43/R
8	23	Sörmland	Nyköping	Trafikverket	E4	34/P
2013						
5	26	O	Strömstad	Trafikverket	Lv1027	21/R
5	26	T	Askersund	Trafikverket	LV205	30/R
6	24	K	Ronneby	Trafikverket	E22	27/R
7	27	H	Oskarshamn	Trafikverket	LV771	38/R
9	21	O	Partille	Trafikverket	E20	44/R
2012						
7	12	X	Gävle	Trafikverket	E4	63/R
2011						
4	24	AB	Nacka	Kommun	Local street	44/R
5	20	AB	Sollentuna	Trafikverket	E4	39/R
5	21	LM	Ängelholm	Trafikverket	E6	20/R
6	26	AC	Umeå	Trafikverket	E4	38/R
7	30	AB	Vallentuna	Trafikverket	LV280	65/R
2010						
7	10	Y	Sundsvall	Trafikverket	E4	43/R
8	7	D	Nyköping	Trafikverket	E4	56/R
9	8	AB	Stockholm	Trafikverket	E4	18/R
9	10	O	Göteborg	Trafikverket	E45	30/R
9	27	LM	Örkelljunga	Trafikverket	A ALLM VÄG	21/R
2009						
6	15		Göteborg	Kommun	Local street	33/R
7	30		Älvsbyn	Trafikverket	LV 555	58/R
8	20		Kungälv	Trafikverket	E 6 MV	45/R
2008						
6	6	O	Göteborg	Trafikverket	A ALLM V	21/R
6	21	LM	Helsingborg	Gata	25/R	
8	2	O	Göteborg	Trafikverket	E6/RV 45	42/R
8	6	F	Jönköping	Trafikverket	E4	48/R
8	24	X	Gävle	Trafikverket	RV 80	42/R

2007							
6	4	BD	Luleå	Trafikverket	E4 MV	59/R	
8	23	BD	Luleå	Kommun	Local street	29/R	
2006							
6	21	K	Ronneby	Trafikverket	RV 27	23/R	
6	8	S	Karlstad	Trafikverket	E18	29/R	
6	14	AC	Umeå	Trafikverket	E4 MV	40/R	
8	1	H	Västervik	Trafikverket	LV786	42/R	
4	23	AC	Robertsfors	Trafikverket	LV 670	52/R	
6	15	K	Olofström	Trafikverket	LV 538	56/R	
2005							
10	1	D	Trosa	Trafikverket	LV 219	20/R	
6	3	F	Jönköping	Trafikverket	RV 40	23/R	
8	1	T	Kumla	Trafikverket	LV 529	25/R	
7	27	T	Karlskoga	Trafikverket	E 18	58/R	
2004							
4	15	O	Ale	Trafikverket	RV 45	25/R	
5	22	U	Köping	Trafikverket	E 18	40/R	
5	27	AB	Stockholm	Kommun	Local street	27/R	
6	24	LM	Vellinge	Trafikverket	E 6	32/R	
8	14	LM	Helsingborg	Trafikverket	E4 MV	22/R	
9	18	LM	Lund	Trafikverket	LV 945	16/P	
2003							
8	20	W	Leksand	Trafikverket	LV 919	24/R	
2002							
4	12	T	Kumla	Kommun	Local street	22/R	
7	28	U	Västerås	Trafikverket	E18	24/R	
8	24	W	Hedemora	Trafikverket	LV270	45/R	
2001							
8	19	AB	Vaxholm	Trafikverket	LV274	21/R	
7	28	T	Ljusn-Berg	Trafikverket	LV792	33/R	
2000							
7	28	AB	Vaxholm	Trafikverket	LV1002	28/R	
8	1	D	Katrineholm	Trafikverket	LV216	30/R	
7	9	N	Kungsbacka	Trafikverket	E6	45/R	

Average age: 36 years. Two women, one passenger, one rider. Two passengers, 55 riders. Most fatal barrier accidents on the following roads:

E4 13

E6 5

E18 4

E16, E22, E20 and E45= one fatal accident on each road. In total 26 fatal accidents on the TENT roads which means 45,6 percent. Six fatal accidents on local authority roads/streets, 51 on the state owned roads.

APPENDIX 3. EXAMPLES OF BARRIERS IN EACH CLASS

Barriers class -1



Barriers class 0

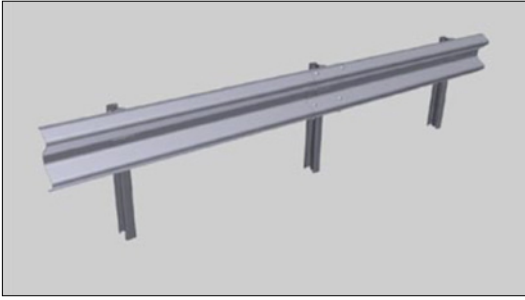

W-profil



Kohlschwa

Barriers class 1



Rooftop barrier



Roof rack with smooth profile on top



Barriers class 2



Barriers class 3



Barriers class 4



Bild 5: System EuskirchenPlus nach [GÄRTNER]



Bild 24: Querschnitt am Sigma-Pfosten der EDSP-Motorrad für die Variante mit Schutzplankenholm Profil A

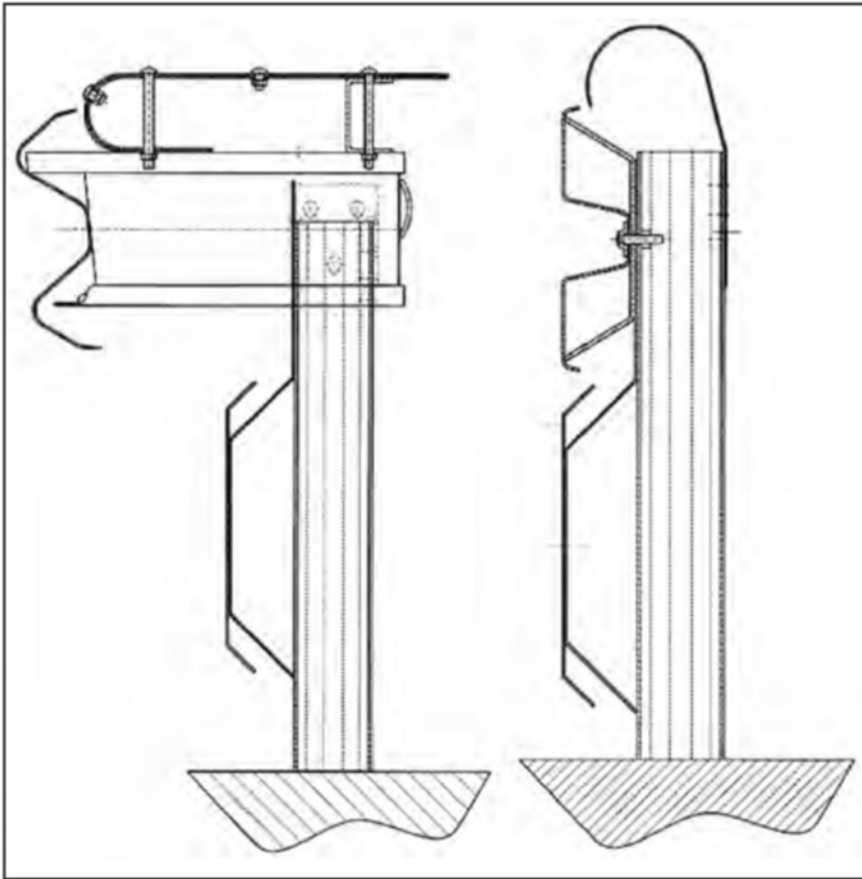

Bild 22: Frontansicht EDSP-Motorrad mit Anordnung der Unterfahrerschutz- und Oberzugelemente. Die Stützbügel für den Oberzug werden auf den Abstandhaltern verschraubt (Abstand: 2 m). Die Aufhängebügel des Unterfahrerschutzes werden vor jedem Sigma-Pfosten montiert (Abstand: 2 m)

APPENDIX 4: NOTES FROM THE WORKSHOP IN SOLLENTUNA 20TH FEBRUARY 2015

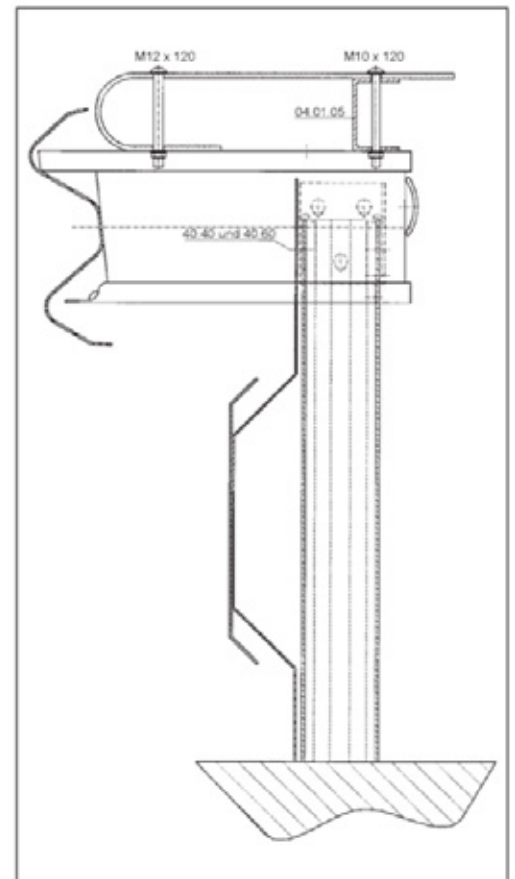
An invitation was sent out at the beginning of 2015 to our network and anyone who could be concerned within the Swedish Transport Administration and to scientists, bikers, insurance companies, barrier manufacturers and consultants. In addition to the presentation of the literature study two researchers were invited: Uwe Ellmers from BAST in Germany, and Clay H Gabler, from Virginia Tech in USA.

The literature review was presented by Göran Fredriksson and Maria Nordqvist. The meeting asked for a development of the classification scheme with MC-friendly guard rail properties. It was presented as a concept linked to the results of the research done and the outcome of the literature study.

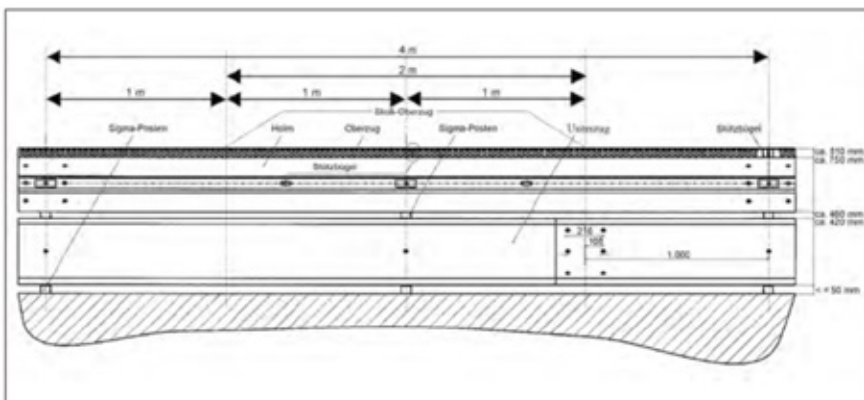
Clay Gabler, Virginia Tech

Clay Gabler presented the results of research from the United States. He has conducted several studies over a number of years and has drawn attention to the high number of motorcyclists killed in guard rail accidents. Since 2004 more motorcyclists than motorists have died in guard rail accidents in USA. 45 percent of those who are killed in collisions with the guard rails are motorcyclists.

Gabler examined several databases and compared the risk of being killed in a collision depending on what you collide with. He showed that the risk of death is higher in collision with both concrete and W-beam rail compared to a collision motorcycle - car where the risk is 4.8 percent. The risk of death is 80 times higher for motorcyclists who collide with a guard rail compared to those who are traveling in a car. The risk of being killed in a collision with W-profile barrier is 13.7 percent while the risk of being killed in collision with the concrete barrier is 8.2 percent. Thus Gabler concludes that the risk of serious injury is 1.4 times higher at collision with W-profile compared to a concrete barrier. The studies made by Gabler have not shown any significant difference in a collision with a cable barrier compared to a w-profile barrier. 951 accidents in four states have been investigated; Texas, Maryland, North Carolina and New Jersey. 35 percent of the accidents were fatal accidents and serious injuries. The risk of being seriously injured increased if the motorcyclist was separated from the motorcycle, the motorcyclist slid on the road towards the barrier and how the collision with the guard rail occurred. The collisions did not lead to laceration. Many accidents occurred on entrances and exits from highways.

Clay proposes various measures to reduce the risk of injury for motorcyclists who crashes with barriers; improve the top of the rail, avoid pole tops with sharp edges and attach MPS in front of the posts. This gives smoother guard rails. There is only one MPS installed in the entire USA.

One thing of Clay's presentation that drew the attention of all participants was the generous space between the road and the median barrier. An American cable barrier may also have eight meters between the posts. Cable barriers are often further from the paved edge of the road in the USA compared to both concrete and w-profile barriers which can affect the outcome of a guard rail collision positive since the speed drops before the collision with the barrier. Clay agreed with this and admitted that this had not been taken into account when looking at injury outcomes.



Picture 1. Median cable barrier installation in USA



Picture 2. Cable barrier installation 2+1 in Sweden (Finspång-Norrköping).

The following discussion was about installation of MPS at black spots. Maria Wedin, Länsförsäkringar, told the audience about their collection of all injuries in the traffic on a map, "Skada på karta". SMC described the project "10 000 kilometers road" where all motorcycle accidents in STRADA 2003 - 2009 are included along with the roads that are identified as the most important motorcycle roads in Sweden: <http://www.svmc.se/smc/SMCs-arbete--fragor/Infrastruktur/Bakgrundshistoria/>

There are old guard rails on the roads which are of really low quality. One issue discussed was why the insurance companies only replace the existing guard rail in case of an accident. Instead they can give funding that makes it possible to mount a safer rail when the damaged guard rail should be replaced. This is something that will be discussed among the insurance companies. Uwe Ellmers from BAST proposes that the classification scheme of guard rails should be used in these contexts.

The question of why Sweden has a lower standard compared to the rest of Europe when it comes to the guard rail height was raised once again. A lower barrier increases the risk of motorcyclists to fall over it and usually lower barriers have less ability to hold back larger and higher vehicles such as SUVs. This was also found in the USA a few years ago and followed by a general increase of the barriers installed. The difference in price on a barrier that is 5-10 cm higher is negligible. The reason for the lower height in Sweden is historic and the reasons yet unknown. The reason that nothing is done to increase the height depends, however, mostly on formal issues to formulate the requirements of the Swedish Transport Administration.

Uwe Ellmers, BAST

Germany began the work to increase motorcycle safety concerning barriers and other actions many years ago. This is really not science but is primarily about "best practice". The criteria for MPS was formed already 2004. In 2007, the MVMOT guidelines was published which describes how the infrastructure can be improved for motorcyclists. The guidelines have still not been implemented, partly because of cost and partly because they are optional to implement. There is a great potential for improvement of the road environment to increase the safety for motorcyclists.

There are 28,000 motorcycle accidents in Germany every year. 650 are fatal accidents and 15 percent of the fatalities are guard rail accidents. However, it is also important to reduce serious injuries, since the barriers are involved in 16 percent of serious injuries and 31 percent of those who die outside urban areas. The guard rail design contributes to a more serious injury outcome of the accident. The number of seriously injured could be reduced with about 15 percent with MPS on guard rails. Most motorcycle accidents with barriers in Germany are on the smaller and curvy roads. However, there are also a lot of accidents on the exits from the motorway.

The German crash tests have been made by BAST both with the dummy seated on the motorcycle and sliding into the guard rail. For BAST it is important to test both scenarios. The first MC-friendly railing that was first used was box beam barrier with MPS.



Picture 3. Box beam barrier with MPS, Germany.

The development and testing continued where the last step was Euskirchen Plus. This barrier also has a protection for the top of the barrier. Tests have been made with both cars and motorcycles which show that this is a better option than the MPS previously used in Germany. This MPS is however only installed in one place. It is not designed to be easy to assemble and therefore it is difficult and expensive to install.

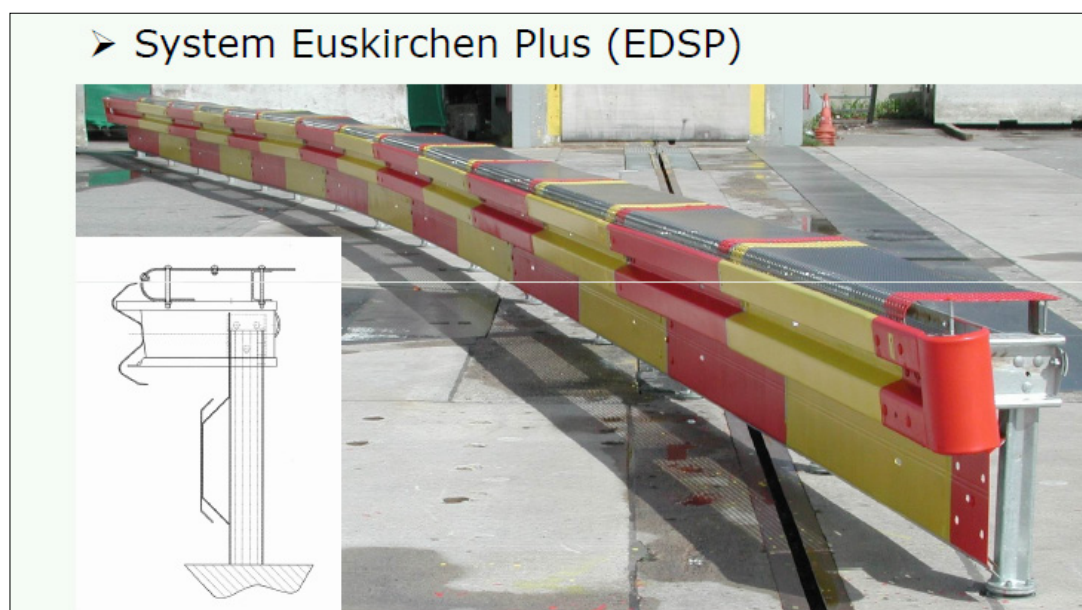

Photo 4. Euskirchen Plus, Germany.

There are several opportunities in Germany that can be used to increase the safety of motorcyclists regarding guard rails. It is however a long-term process and the work must begin immediately. Uwe believes what can be used in Germany should work well also in Sweden. These measures are:

- Use the technical guidelines to increase safety on the most popular motorcycle roads
- Consider the development of active and passive safety in vehicles
- Use the proposed measures to improve motorcycle safety at accident black spots (BAST Report V 152)
- Audit of the regulatory framework for passive safety through safety barriers to be produced in Germany
- Finish the development work on the MPS and write recommendations
- Implement all this in practice

During the discussions following the interesting presentation with loads of test films Uwe told the audience that cable barriers are not used in Germany, they have always been prohibited. MPS is used almost exclusively in outer bends on curvy roads, since these are the places where most motorcyclists are injured or/and killed in guard rail accidents. It is important that TS 1317-8 becomes a standard for MPS since the specification available today is not compulsory. Uwe states that it is important to listen to the consumers - users.

Concluding discussion

Morten Hansen, NMCU Norway, held a speech about how the work to develop and install MPS on Norwegian roads progresses. An analysis of all fatal accidents have been conducted. It showed that 34 percent of all fatal accidents have occurred in a collision with an obstacle installed by the road owner in the actual safety zone of the road. A Vision Zero Road was created in 2008 in which a wide range of measures were taken, including installation of MPS in some curves. There have not been any problems with maintenance during winter or summer. Recently, there was a severe motorcycle accident on this road against the MPS, made of plastic. The motorcyclist survived without any injuries. The installation of MPS is only a recommendation for curves with a certain radius but at the same time a part of the Norwegian MC strategy for increased motorcycle safety as well as a part of the Norwegian handbook for rekkverk (N101). There is no need for more research in Sweden or other countries, says Morten. However there is a need for brave people who dare to take the necessary decisions. The Swedish Transport Administration must start a systematic effort to create a safer road environment for motorcyclists. He suggests that the classification scheme is further developed and that someone looks for funding to create an implementation model of the scheme.

Hans Holmén, the Swedish Transport Administration, announces that the 3-year project regarding evaluation of MPS from a maintenance point of view, mainly winter, will be completed in 2015 with a final report.

Several manufacturers pointed out the need of a market demand for MPS, which only the Swedish Transport Administration can achieve, as well as a standard and guidelines from the Swedish Transport Administration to develop MPS and/or safer barriers for motorcyclists. Sweden cannot accept approved products from other countries. Myrko Bellman, Volkmann & Roszbach, saw no connection between the standard and demand. The current standard is not good. Another problem is that the guidelines for road design almost always includes new construction, not renovation and maintenance of roads.

Would you rather be able to imagine an open standard? According to Wikipedia, an open standard, is a standard that, in contrast to a proprietary technical specification, allows anyone to implement it without the owner of the standard sets up unreasonable or discriminatory barrier. This enables interoperability between products from different manufacturers are following the standard, and free competition between the developers of these products.

Birstaverken suggested that the SMC creates an open standard. SMC could raise funds through crowd-funding. SMC will investigate this issue but it is important that the Swedish Transport Administration accepts a standard created by a motorcycle organization. The conclusion was that an open standard SMC would be welcomed. Estimated cost is approximately 150 000 SEK.

Birstaverken was asked about the cost of the MPS. If they would get orders for large volumes for w-profile + MPS the cost would increase by approximately € 20 per meter, installed and ready.

Myrko Bellman, Volkmann & Roszbach, says that member countries are not allowed to write a national standard when there is already a technical specification. The question is whether we can try to get rid of the specification in favor of an open standard instead? The issue must be addressed within CEN.

The meeting ended with Maria Nordqvist promised to write report of the meeting and to incorporate the comments in the final report.



Sveriges MotorCyklister

The Swedish Motorcyclists Association, SMC, is a non-profit making organization. SMC has around 70 000 members. The most important fields of action for SMC is road safety, tourism, insurances, consumer issues, information and national and international advocacy for the motorcyclists.